

Granaria ORC Polish Open Championship 2017

Sailing Instructions

1 Organizing Authority

The ORC European Championship 2017 is organized by the Pomeranian Sailing Association in conjunction with City of Gdansk under the authority of the Polish Sailing Association and under the overall authority of the Offshore Racing Congress (ORC) and the World Sailing (WS).

2 Rules

2.1 The regatta will be governed by the rules as defined in The Racing Rules of Sailing (RRS).

2.2 The following rules will also apply:

- a) IMS Rule
- b) ORC Rating Systems Rule
- d) World Sailing Offshore Special Regulations - all races will be Category 4.

2.3 No national authority prescription will apply.

[DP] 2.4 Under RRS 87, ORC Rule 206 is changed as follows:

- a) All sails shall have been measured and stamped by an ORC measurer. During the pre-race equipment inspection, sails will be marked for the event by stamp, sticker and/or inspector's signature.
- b) The maximum number of sails shall be as defined in ORC Rule 206 with one additional mainsail allowed. The second mainsail shall have a minimum of one set of reef points. The mainsails may be interchangeable.
- c) With the exception of the second mainsail all sails shall be aboard while racing.
- d) Sails damaged during the series may be repaired. Sails beyond repair may be replaced with permission of the Technical Committee

2.5 Under RRS 87 following changes to the ORC Rating systems are made and approved by the ORC:

- a) in ORC Rule 305.2 words "Race Committee" are replaced by "Technical Committee".
- b) in ORC Rule 305.2(c) words "50% place penalty" are replaced by "50% of the score for Did not Finish, rounded to the nearest whole number (0.5 rounded upward)

2.6 If there is a conflict between languages the English text will take precedence.

2.7 Part 2 of the Racing Rules of Sailing is replaced during night by Part B of the International Regulations for Preventing Collisions at Sea from **21:00** to **05:00** local time. In any of these sailing instructions, a reference to "night" means the period prescribed above.

[DP] 2.8 Appendix 1 of these SI shall apply for the bow numbers. Protests on the bow numbers can be lodged only by the Race Committee. This changes RRS 60.1 and 60.3.

[DP] 2.9 A breach of RRS 48.2 or RRS 49.2 shall not be grounds for protest by a boat. This changes RRS 60.1 (a).

3 Classes

3.1 Boats will be divided in Classes according to the Notice of Race requirements as follows:

- Class A: 17.0 >= CDL > 11.5
- Class B: 11.5 >= CDL > 9.65
- Class C: 9.65 >= CDL > 8.00
- Class D: 8.00 >= CDL

Classes will have separate starts and separate results.

- 3.2 Any change to CDL after applying ORC rule 305.2(b) shall not change the class that boat originally entered.

4 Notices to competitors

Notices to competitors will be posted on the official notice board(s) located at Regatta Village at Szafarnia Street. Notices will also be posted on the event website. Failure or delay to post the notice on the event website will not be ground for request for redress by the boat. This changes RRS 60.1(b).

5 Changes to Sailing Instructions

Any change to the Sailing Instructions will be posted not later than **2 hours** before it will take effect, except that any change to the schedule of races will be posted by **20:00** hours on the day before it will take effect.

6 Signals made ashore

- 6.1 Signals made ashore will be displayed at **Regatta Village at Szafarnia Street**.
- 6.2 When flag AP is displayed ashore '1 minute' is replaced with 'not less than **90** minutes' in race signal AP. This changes race signal AP.

7 Schedule of races

- 7.1 Times of the first warning signals are defined as follows:

| | | |
|----------|--|-----------------------------------|
| Friday | 21th July 2017 11:00 | Inshore race(s) |
| Saturday | 22th July 2017 11:00 | Offshore race |
| Sunday | 23th July 2017 11:00 | Inshore race(s), closing ceremony |

The Organizing Authority and/or the Race Committee reserves the right to modify the above programme according to weather conditions and/or other unforeseen reasons.

- 7.2 Six races are scheduled including:
- one offshore race
 - five inshore races
- 7.3 There will be no more than **3** races per day. Flag **G** displayed on the finishing line means "There will be one more race after the one in progress." The warning signal for the next race will be given one minute after lowering flag **G** with one sound.
- 7.4 On the last day of regatta no warning signal will be given after **14:00**.

8 Class flags

The Class flags will be:

Class A: Red flag with letter A
Class B: Blue flag with letter B
Class C: Grey flag with letter C
Class D: Purple flag with letter D

9 The Start

- 9.1 A boat starting later than 4 minutes in the inshore races and 10 minutes in the offshore race after her Start signal will be scored DNS. This changes RRS A4.1.

- 9.2 After signalling an individual recall, the race committee will attempt to broadcast the sail number, bow number or name of boat that has not started and is identified as OCS on VHF channel **72 – Area 1, 77 – Area 2**. Delay in the radio broadcast of these calls, or the order in which they are made, or any omission or failure in the transmission or reception of these, will not be grounds for a request for redress by a boat. This changes RRS 60.1(b).

10 Penalty system

- 10.1 The penalty for breaking a rule of Part 2 while outside the zone of a rounding mark will be a One-Turn penalty. This changes RRS 44.1.

- 10.2 For the offshore race, RRS 28 is changed as follows:

(a) In rule 28.1, delete the first sentence and replace with:
'A boat shall cross the starting line after having been entirely on the pre-start side at or after her starting signal and sail the course described in the sailing instructions and *finish*.'

(b) In rule 28.2, delete the first sentence and replace with:
'A string representing a boat's track from the time she begins to approach the starting line from its pre-start side to cross it until she *finishes* shall, when drawn taut, ...'

[DP]

(c) Add new rule 28.3 Penalty:

A boat that does not cross the starting line as required by rule 28.1 will receive the 20% scoring penalty as defined in RRS 44.3. However, a boat that gains a significant advantage in the race by breaking rule 28.1 despite this scoring penalty may be protested and penalised; any such penalty resulting from such a protest may be less than disqualification. This changes RRS A4 and A5.

- 10.4 For minor breaches of the Offshore Special Regulations, RRS 55 and any Sailing Instruction marked with [DP] the jury may impose any penalty different from Disqualification, or not impose a penalty, at its discretion. The maximum discretionary penalty for the minor infringements of the Offshore Special Regulations will be the scoring penalty of 10% calculated in accordance with RRS 44.3(c).

11 Protests and requests for redress

- 11.1 Protest forms are available at the Jury Office located in building "Superior". Protests shall be delivered there within the time limit which shall be:

a) for inshore races: **2** hours after the last boat has finished the last race of day for the relevant class, or the race committee signal 'no more racing today', or 30 minutes after the race committee signal 'no more racing today' is displayed ashore. The same time limit applies to protests by the race committee and international jury about incidents they observe in the racing area and to requests for redress. This changes RRS 61.3 and 62.2.

b) for the offshore race: **2** hours after protestor's finish.

- 11.2 A measurement protest by a boat shall not be accepted after Friday 28th of July at 20:00. This changes RRS 60.1(a) and 61.3.

- 11.3 Notice of protests by the Race Committee, International Jury or Technical Committee will be posted on the official notice board to inform competitors under RRS 61.1(b).

- 11.4 Notices to inform competitors of hearings in which they are parties or named as witnesses will be posted:

a) for inshore races within 30 minutes of the protest time limit.

b) for the offshore race, within 30 minutes of the finish of all the boats involved in the protest.

- 11.5 On the last day of the regatta a request for reopening a hearing or request for redress for a jury decision shall be delivered:

a) within the protest time limit if the party requesting reopening was informed of the decision on the previous day

b) no later than 30 minutes after the party requesting reopening was informed of the decision on that day

This changes RRS 62.2 and 66.

11.6 When RRS N1.4(b) is applied the time limit will be 30 minutes after the decision is given.

11.7 The decisions of the International Jury will be final as provided in RRS 70.5.

12 Scoring

12.1 Inshore race results will be determined by corrected times calculated by the Performance Curve Scoring and constructed course scoring method

12.2 Offshore race results will be determined by corrected times calculated by the Ocean for PCS scoring method.

12.3 The decision on the scoring method and scoring parameters used will be at the sole discretion of the Race Committee and together with length of course, directions of leg and the wind speed will not be grounds for request for redress by the boat. This changes RRS 60.1(b).

12.4 The championship is valid if at least 3 inshore races and the offshore race are completed. One score will be excluded if 5 or more races are completed,

13 Safety regulations

[DP] 13.1 Boats retiring for any reason in any race shall report to the Race Committee as soon as possible.

[DP] 13.2 Any use of the engine for propulsion purposes for rescuing people, giving help or any other reason shall be reported after arrival in written form to the Race Committee stating reasons for such procedure. If a boat does not gain a significant advantage in the race, the International Jury may impose a discretionary penalty.

14 Replacement of crew or equipment

[DP] 14.1 The Race Committee may approve crew changes (adding new crew members, replacing or disembarking crew members) by written skipper's request made no later than 2 hours before the scheduled time of the start of the first race of the day. The substituted crew member shall not be aboard on any other competing boat throughout the remainder of the series. Crew substitutions in Corinthian Division shall also be valid World Sailing group 1 sailors. If not, the entry will be scored in the Open Division.

[DP] 14.2 Substitution of damaged or lost equipment will be not allowed unless approved by the Technical Committee. Requests for substitution shall be made to the Technical Committee at the first reasonable opportunity.

15 Equipment and measurement checks

A boat or equipment may be inspected at any time for compliance with class rules and Sailing Instructions. On the water or after arriving in harbour, a boat may be instructed by the measurer including on VHF channels **72 or 77** to proceed immediately for inspection.

16 Official boats

16.1 Official boats will display an **event flag**. Failure of any official boat to display her flag will not be grounds request for redress by a boat. This changes RRS 60.1(b).

16.2 Vessels used by press, photographers, film crews, VIPs etc. are not under the jurisdiction of the Race Committee. Any action by these boats shall not be grounds for a request for redress by a boat. This changes RRS 60.1(b).

[DP] 17 Support boats

Support boats shall be registered at the race office where an identification number will be assigned. Identification shall be visible at all times. All support boats shall keep well clear of the starting area and, after the preparatory signal, shall not approach within 100 meters of any competing boat that is racing. A breach of this SI may result with a scoring penalty against the boat connected and/or withdrawal of permission to be in the racing area for one or more days.

[DP] 18 Haul-out restriction

From 09:00 on 21.07.2017 yachts shall not be hauled out except for the purposes of repairing damage; and only after written permission from the International Jury. While hauled for this purpose, cleaning and polishing of the hull or appendages below the waterline will not be permitted. Appendages shall not be removed from the boat during the series.

19 Communication

19.1 Radio communication with Race Committee during the regatta will be on VHF channel **72 or 77**. The Race Committee may give verbal confirmation of any race signal over VHF Channel **72 or 77**. Failure to make a broadcast or to time it accurately will not be grounds for request for redress by the boat. This changes RRS 60.1(b).

[DP] 19.2 Except when communicating with the Race Committee, a boat while racing, shall not transmit or receive communication of any information not publicly available to all boats participating. This changes RRS 41.

20 Trophies and prizes

Prizes will be presented as follows:

- A trophy for the Open Polish Champion in each class.
- Prizes for the boats scoring 2nd and 3rd in each class.
- Medals for Polish Champions in each class.

The organizing authority may also present additional prizes. The complete list of trophies and prizes will be posted on the official notice board before the start of racing.

21 Disclaimer of liability

Competitors participate in the regatta entirely at their own risk, see RRS 4 - Decision to Race. The Organizing Authority, Pomeranian Sailing Association, Polish Sailing Association, ORC and any other party involved in the organization of the regatta will not accept any liability for material damage or personal injury or death sustained in conjunction with or prior to, during, or after the regatta. Each boat owner or his representative accepts these terms by signing the entry form.

[DP] 22 Tracking system

GPS tracking of individual boats will be used for safety purposes; each boat must carry the tracking device given by the OA during the races. It must be switched on and positioned near the backstay or on the top of the deck. The following safety procedure will be followed:

- a) At registration, the Safety Officers, shall personally collect and sign for their tracking device.
- b) The tracking device must be returned to the Race Office at the end of the last race of the day to be recharged. It is a Safety Officers responsibility to recharge every evening the tracking device.
- c) The tracking device must be returned to the Race Office at the end of the last race of the series and before the Prize Giving.

- d) Any boat failing to comply with this procedure, without any reason beyond her control, will be reported to the Race Committee and/or Protest Committee for possible action.
- e) In case of loss, the cost will be charged.

Part 2 - Inshore course

23 Racing Areas

Classes will be assigned to Racing Areas. Classes A and B – Race area 1, Class C, D – Race area 2. Attachment 2 shows approximate race area location.

24 The course

- 24.1 The diagram in Attachment 3 shows the course, including the approximate angles between legs, the order in which marks are to be passed, and the side on which each mark is to be passed.
- 24.2 No later than the warning signal, the RC signal boat will display the approximate compass bearing of the first leg.

25 Marks

- 25.1 Marks 2, 2A, 3S, 3P will be **red cylinders with advertising**.
- 25.1 Marks 1, 1A will be yellow **cylinders with advertising**.
- 25.2 New marks 2, 3S, 3P as provided in instruction 26 will be **yellow cylinders without advertising**, new marks 1 will be **red cylinders without advertising**.

26 Change of the next leg of the course

To change the next leg of the course, the Race Committee will lay a new mark and remove the original mark as soon as practicable. A new windward mark will be placed without mark 1A.

27 Starting line

- 27.1 The starting line for class A, D will be between the staff displaying an orange flag on the Race Committee Boat at the starboard and the mark with pole displaying an orange flag at the port-end.
- 27.2 The starting line for classes B and C will be between the staff displaying an orange flag on the Race Committee Boat at the starboard and the staff displaying an orange flag on the pin end boat at the port-end.

28 Finishing line

The finishing line will be between the staff displaying an orange flag on the Race Committee Boat and the mark with pole displaying an orange flag.

29 Time limit

The time limit for the first boat to finish will be 2 hours. Boats failing to finish within 30 minutes after the first boat sails the course and finishes will be scored Did Not Finish. This changes RRS 35 and A4.

Part 3 - Offshore course

30 The course

The course will be announced on 21th June 2017 during the planned skippers' meeting and posted on the Notice Board at the end of that meeting.

31 Marks

Marks will be announced during the skipper meeting and their locations, except the windward mark described in SI 32, and descriptions posted on the Notice Board at the end of the skippers' meeting.

32 Windward mark

The RC may set a windward mark to obtain a start to windward, if necessary. If the windward mark is set, it will be approximately one nautical mile from the starting area and the RC will, before the warning signal, display a red flag which indicates the mark shall be left to port, or a Green flag indicating the mark shall be left to starboard.

33 Starting line

The starting line will be between the staff displaying an orange flag on the Race Committee Boat at the starboard end and the staff displaying an orange flag on the pin end boat at the port-end.

34 Finishing line

34.1 The Finishing line will be announced during the skippers' meeting and its location posted on the Notice Board at the end of the skippers' meeting.

34.2 The finishing line will be between the staff displaying an orange flag on the Race Committee Boat and the finishing mark.

35 Time limit

The time limits will be announced during the skipper meeting.

[DP] 36 Finishing by night

Boats that finish by night shall illuminate their numbers when finishing, and in case of doubt shall try to identify themselves to the RC after finishing on Channel VHF 72.

APPENDIX 1 - BOW NUMBERS

Bow numbers shall be placed as forward as possible

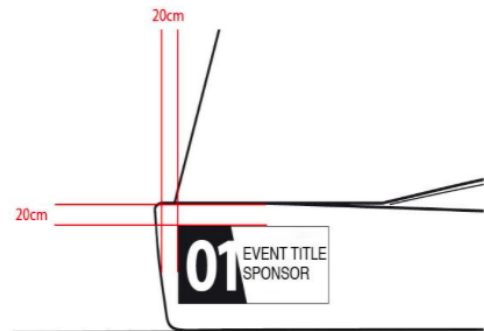
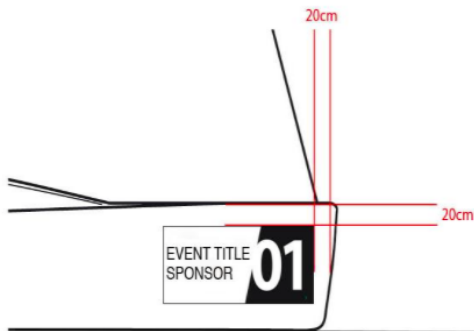

CORRECT



NOT CORRECT



APPENDIX 2 – RACING AREA



Location of middle points:

Area 1: 54°27.520'N 018°36.016'E

Area 2: 54°26.173'N 018°37.499'E

APPENDIX 3 – COURSE DIAGRAM

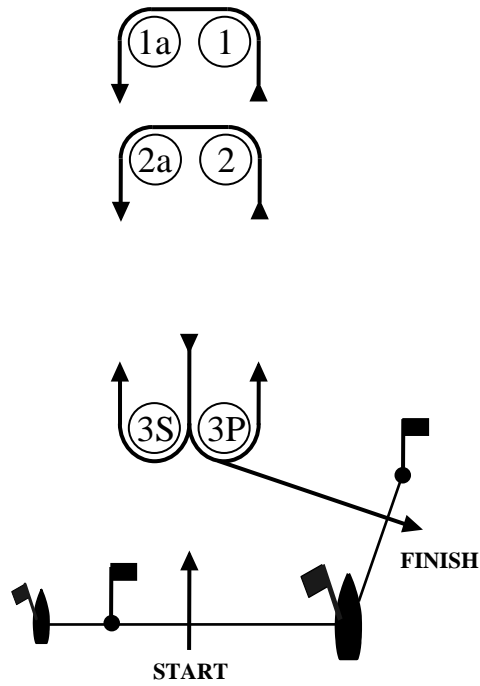

Class A, C

| Mark rounding Order |
|--|
| L2: Start – 1 – 1a – 2s/2p – 1 – 1a – 2p – Finish |
| L3: Start – 1 – 1a – 2s/2p – 1 – 1a – 2s/2p – 1 – 1a – 2p – Finish |

Class B, D

| Mark rounding Order |
|--|
| L2: Start – 2 – 2a – 3s/3p – 2 – 2a – 3p – Finish |
| L3: Start – 2 – 2a – 3s/3p – 2 – 2a – 3s/3p – 2 – 2a – 3p – Finish |